

Porsche 914 GT Replica Wiring Diagrams

Text

Colour Code - Red = Power, Blue = Control, Black = Earth, Orange = HT

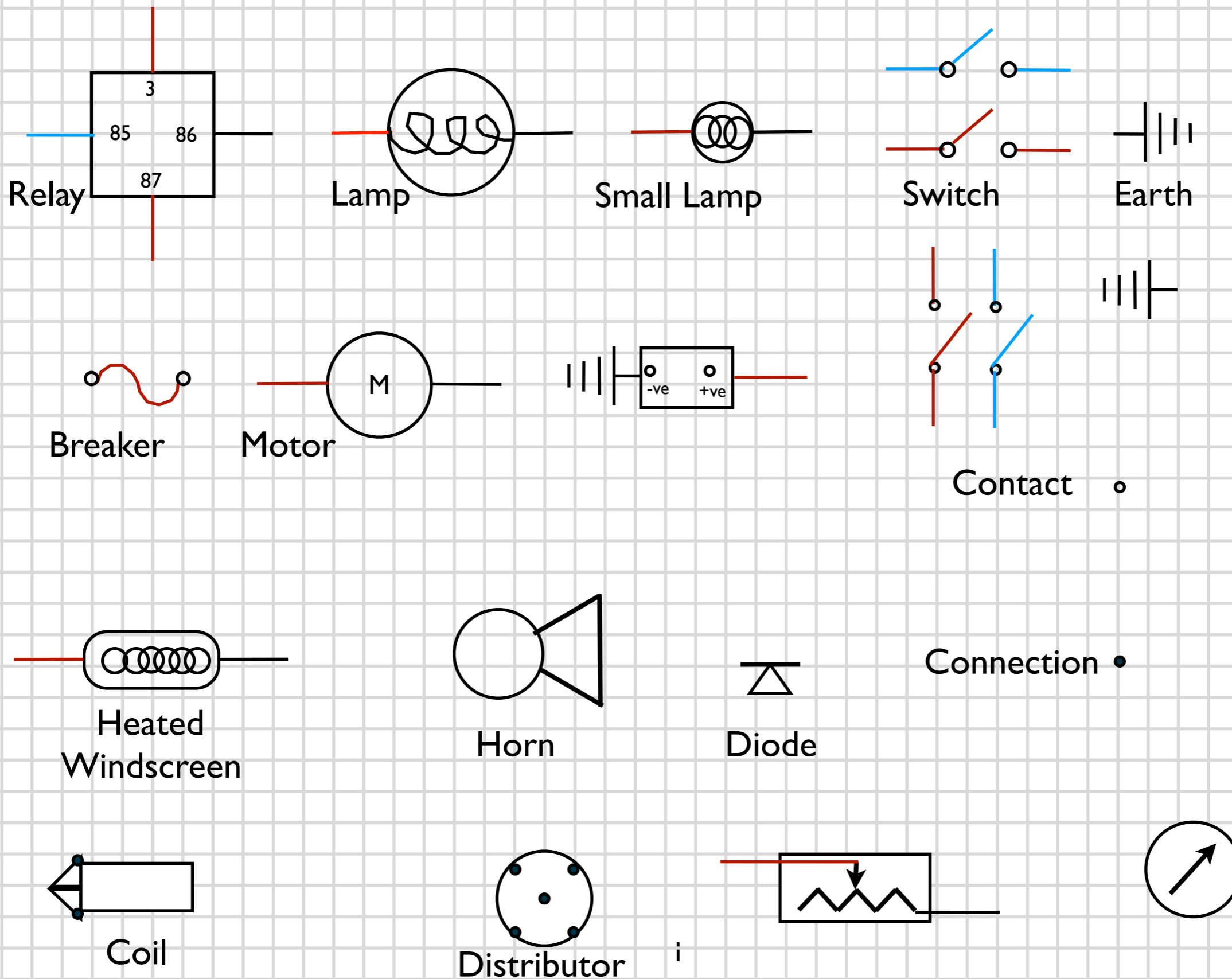

Code System

Systems

- SL=Sidelights
- IG=Ignition
- IN=Indicators
- RE=Reverse Lights
- BR=Brake Lights
- RB=Reverse/Brake
- HL=Headlights
- WW=Windscreen Wipers
- WP=Wipers Park
- WH=Wipers High
- WL=Wipers Low
- WA=Washers
- FP=Fuel Pump
- ST=Starter
- HW=Heated Windscreen
- PS=Power Sockets
- HO=Horn
- SP=Spotlights
- PD=Power Distribution
- FO=Rear Fog Light
- AL - Alternator
- MB=Main Beam
- DB=Dipped Beam
- IS=Instruments
- NL=Navigation Light

Devices

- R=Relay
- L=Lamp
- I=Indication Lamp
- S=Switch
- E=Earth
- B=Breaker
- M=Motor
- A=Accumulator (Battery)
- G=Gauge
- C=Coil
- D=Distributor
- U=Measuring Device
- T=Alternator
- F=Flasher
- Z=Buzzer
- H=Hazard Switch
- O=Socket

Locations

- FN=Front Nearside
- FO=Front Offside
- RN=Rear Nearside
- RO=Rear Offside
- FT=Front Trunk
- RT=Rear Trunk
- EN=Engine Compartment
- PC=Passenger Compartment
- DB=Dashboard

Cable Coding

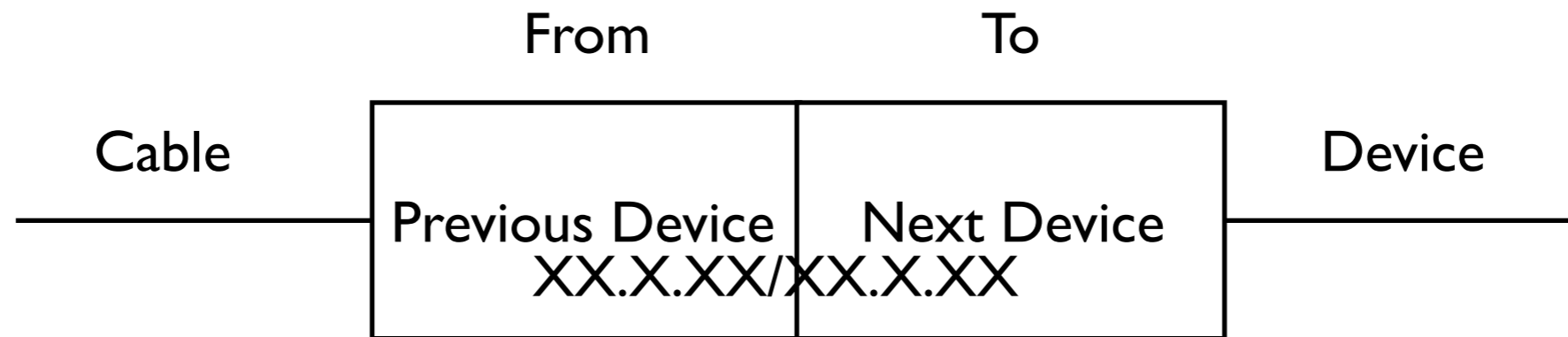

E.G. AC.S.PC/ST.M.EC

Battery.Switch.Passenger Compartment/Starter.Motor.Engine Compartment

SL.S.DB/SL.L.RO

Side Lights.Switch.Dashboard/Side Lights.Lamp.Rear Offside

SP.S.DB/SP.R.DB

Spotlight.Switch.Dashboard/Spotlight.Relay.Dashboard

WW.S.DB.XX = Switch Terminal Number

Power Distribution

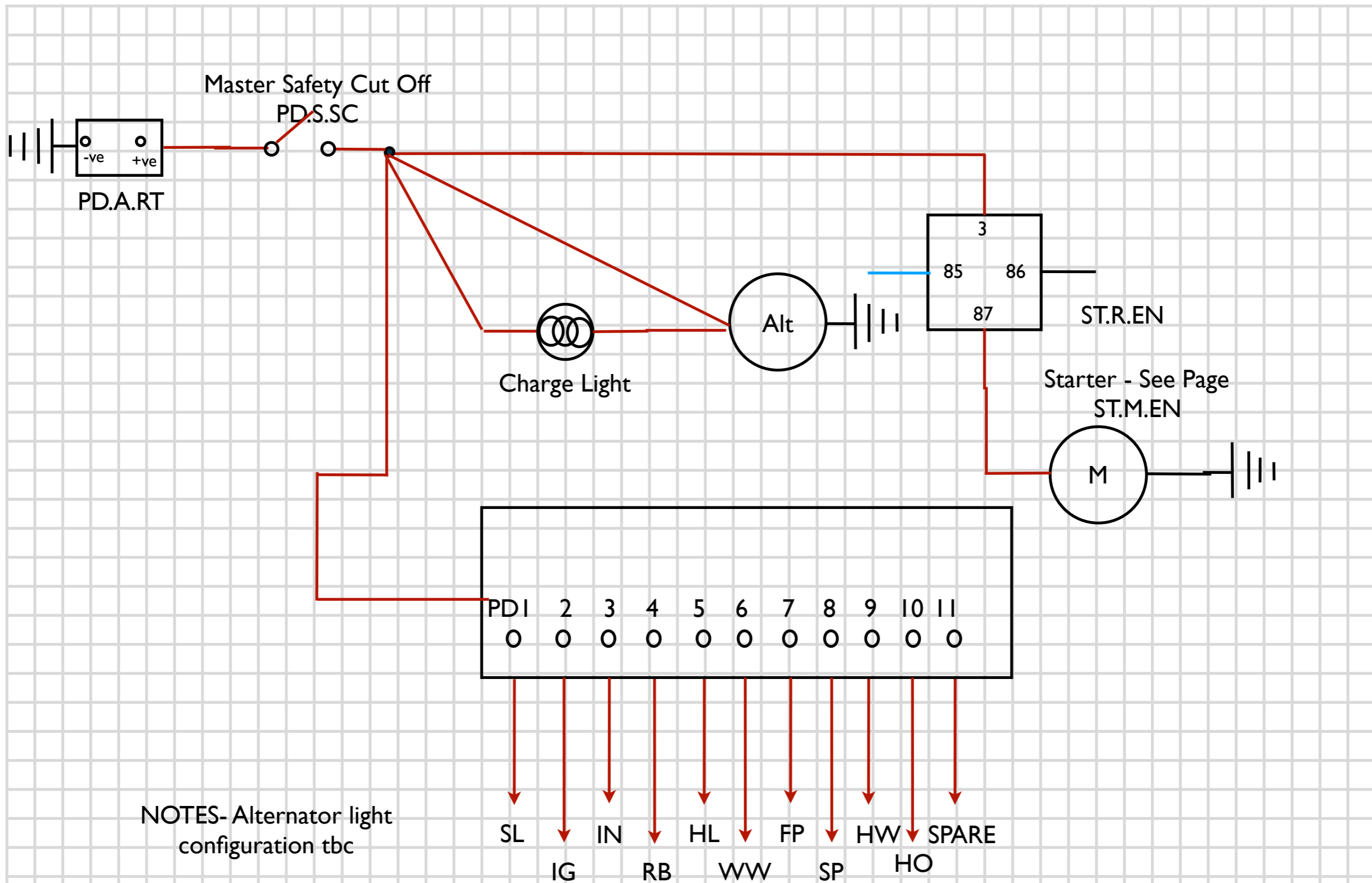

NOTES- Alternator light configuration tbc

Porsche 914 GT Replica Wiring Diagrams
SLC/SLP - Sidelights Control and Sidelights Power
Circuits 1 and 2

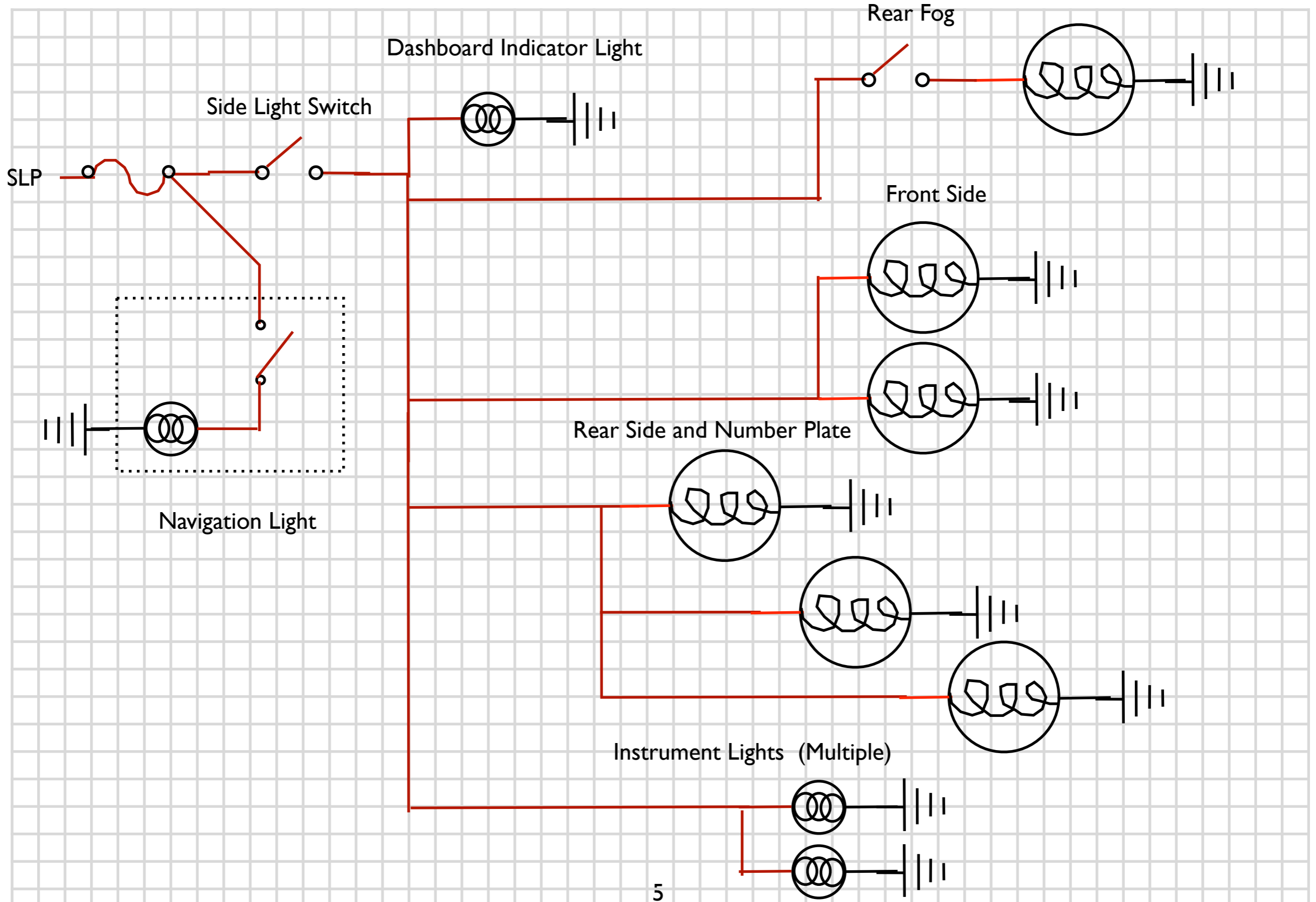

Porsche 914 GT Replica Wiring Diagrams

IGN - Ignition

Circuit 3

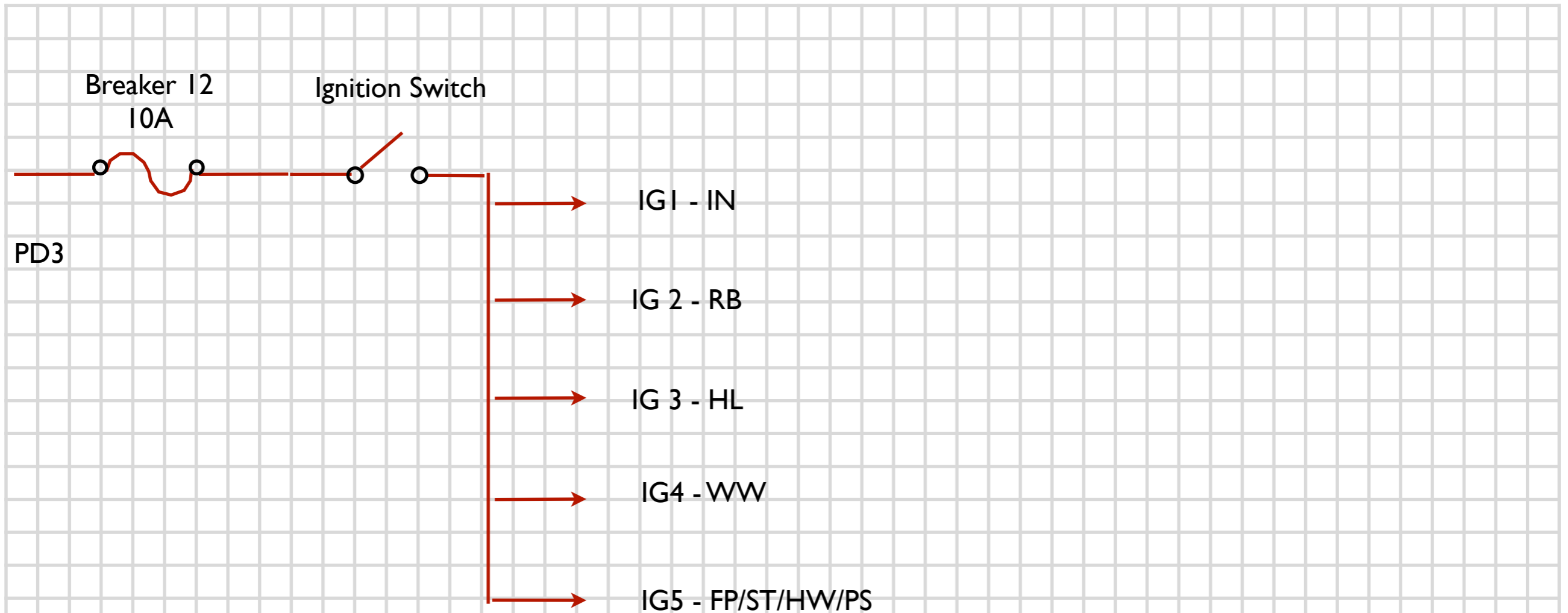

Porsche 914 GT Replica Wiring Diagrams

IND - Indicators

Circuit 4

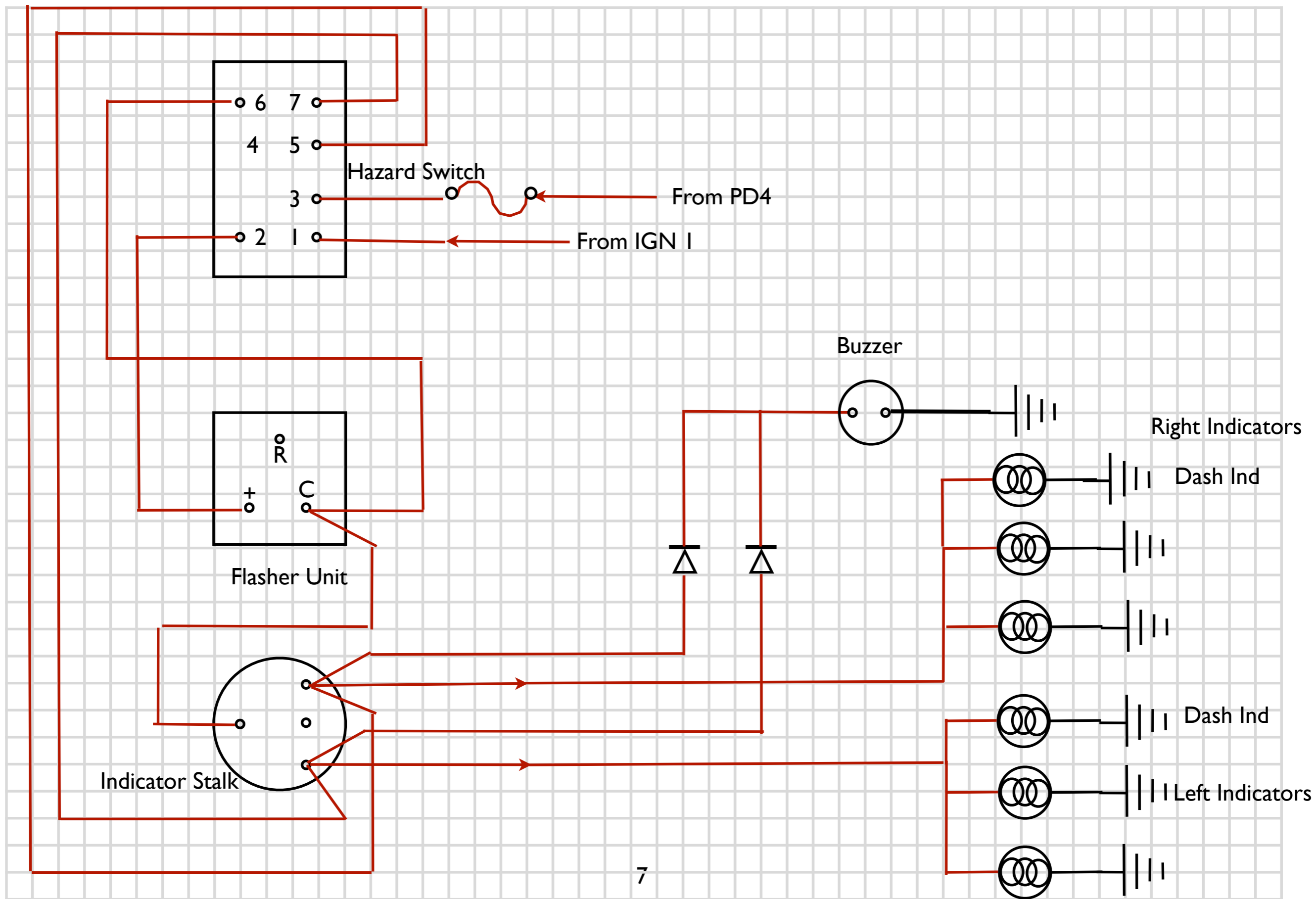

Porsche 914 GT Replica Wiring Diagrams

REB - Reverse and Brake Lights

Circuit 5

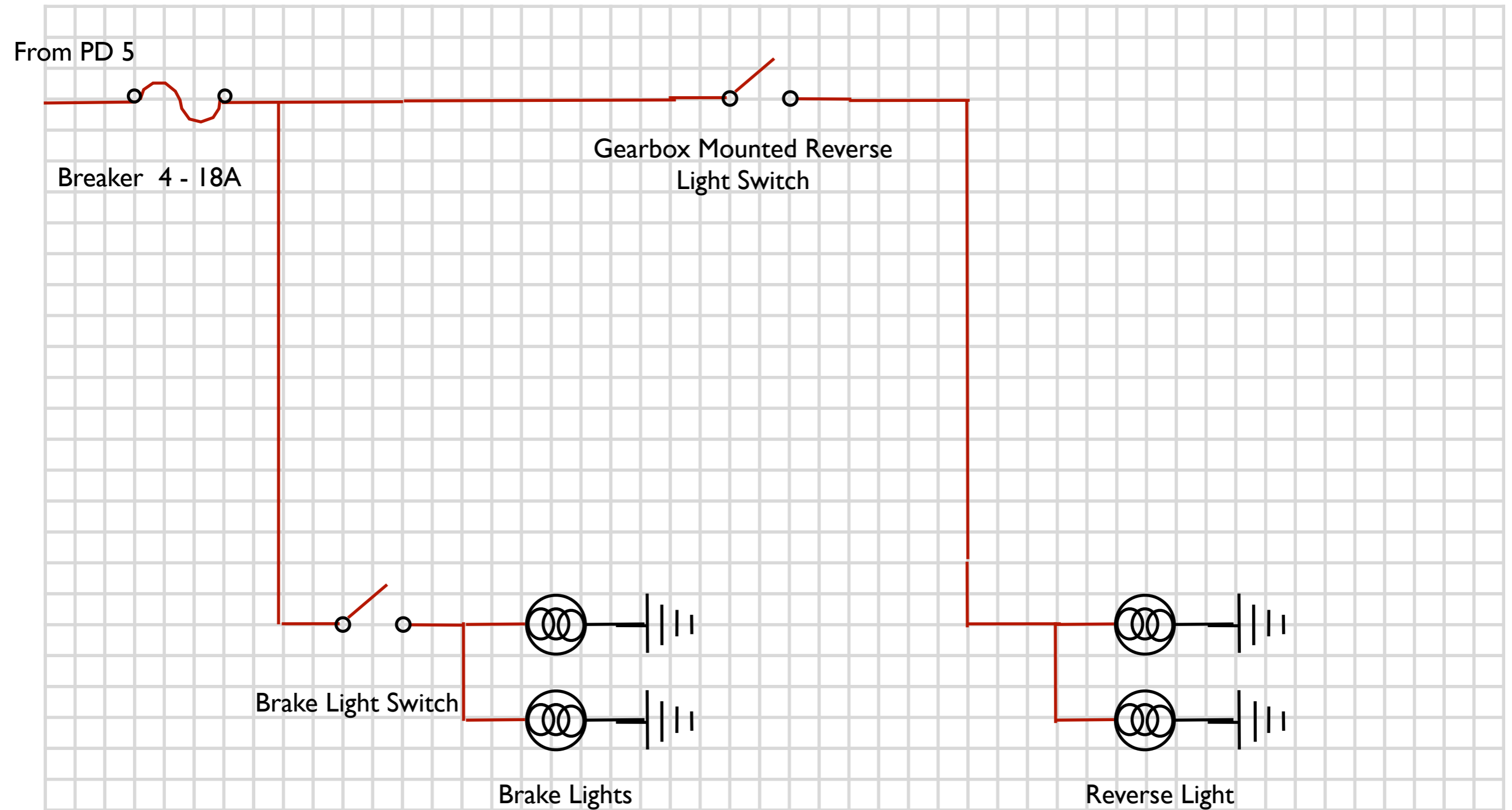

Porsche 914 GT Replica Wiring Diagrams

HLI - Headlights

Circuit 6

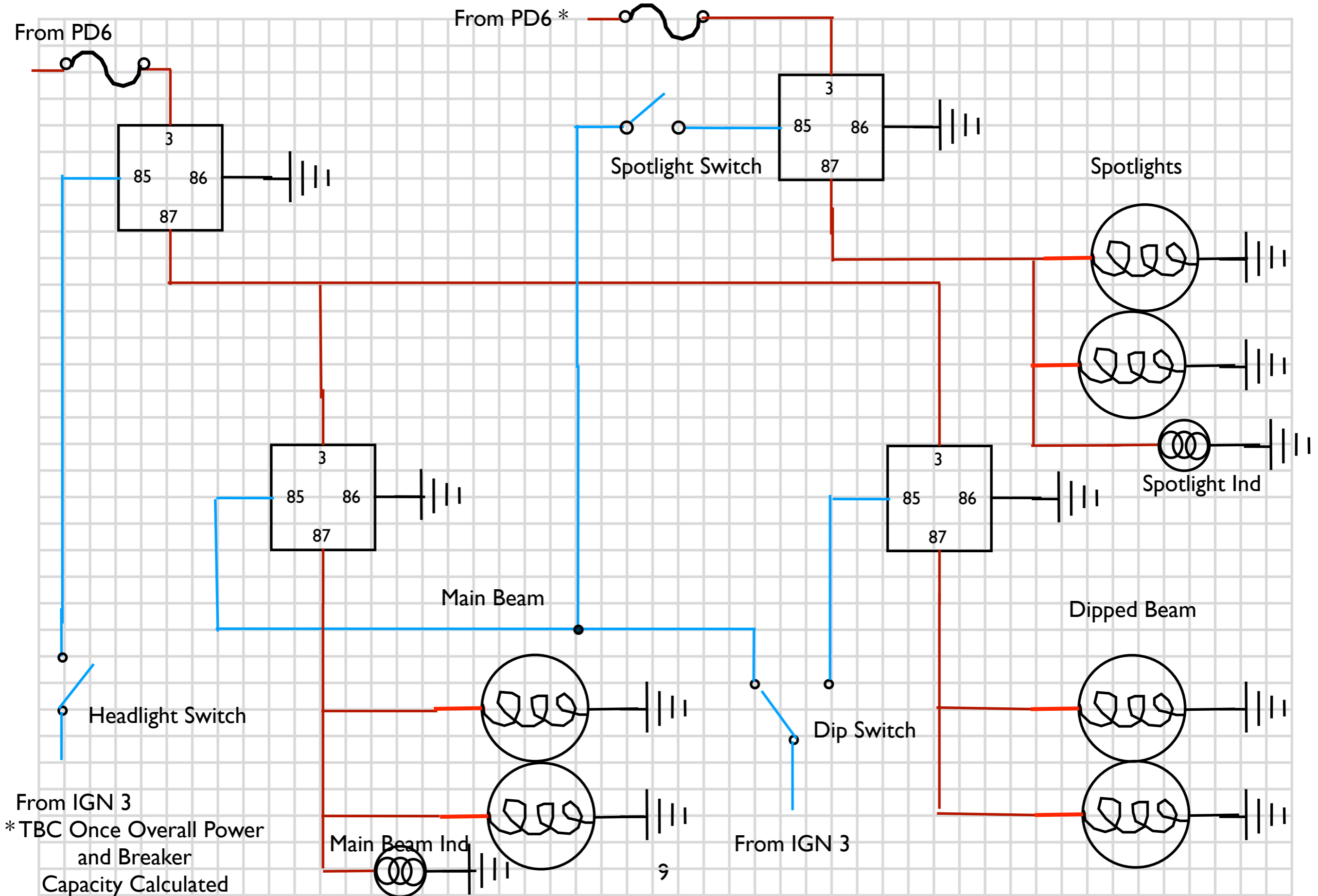

Porsche 914 GT Replica Wiring Diagrams

Circuit 7 - Wipers and Washers

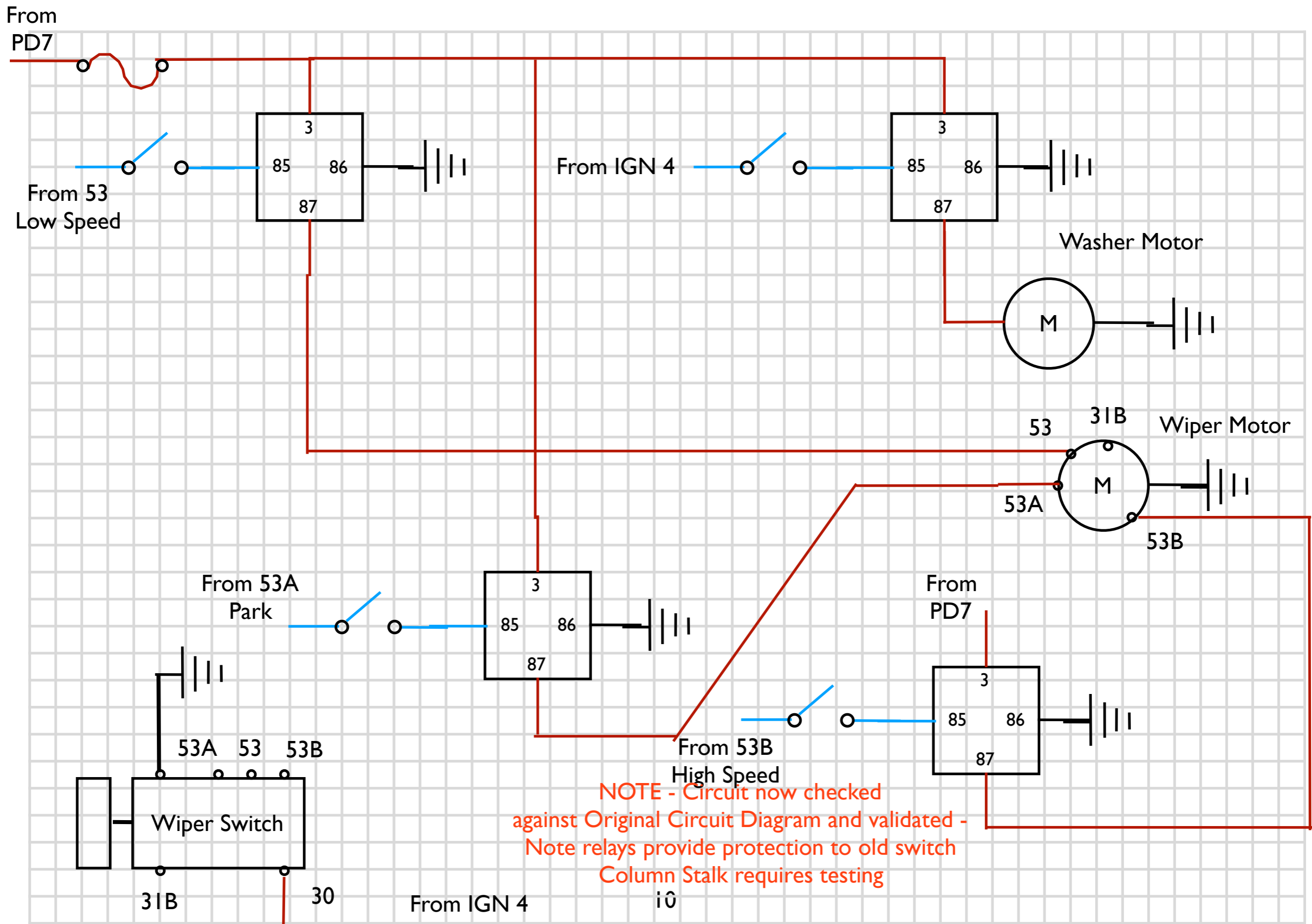

Porsche 914 GT Replica Wiring Diagrams
Circuit 8, 9, 10 - Fuel Pump, Starter, Heated Windscreen, USB Power
(Note - Starter, HWS, and coil only Live when Fuel Pump Running)

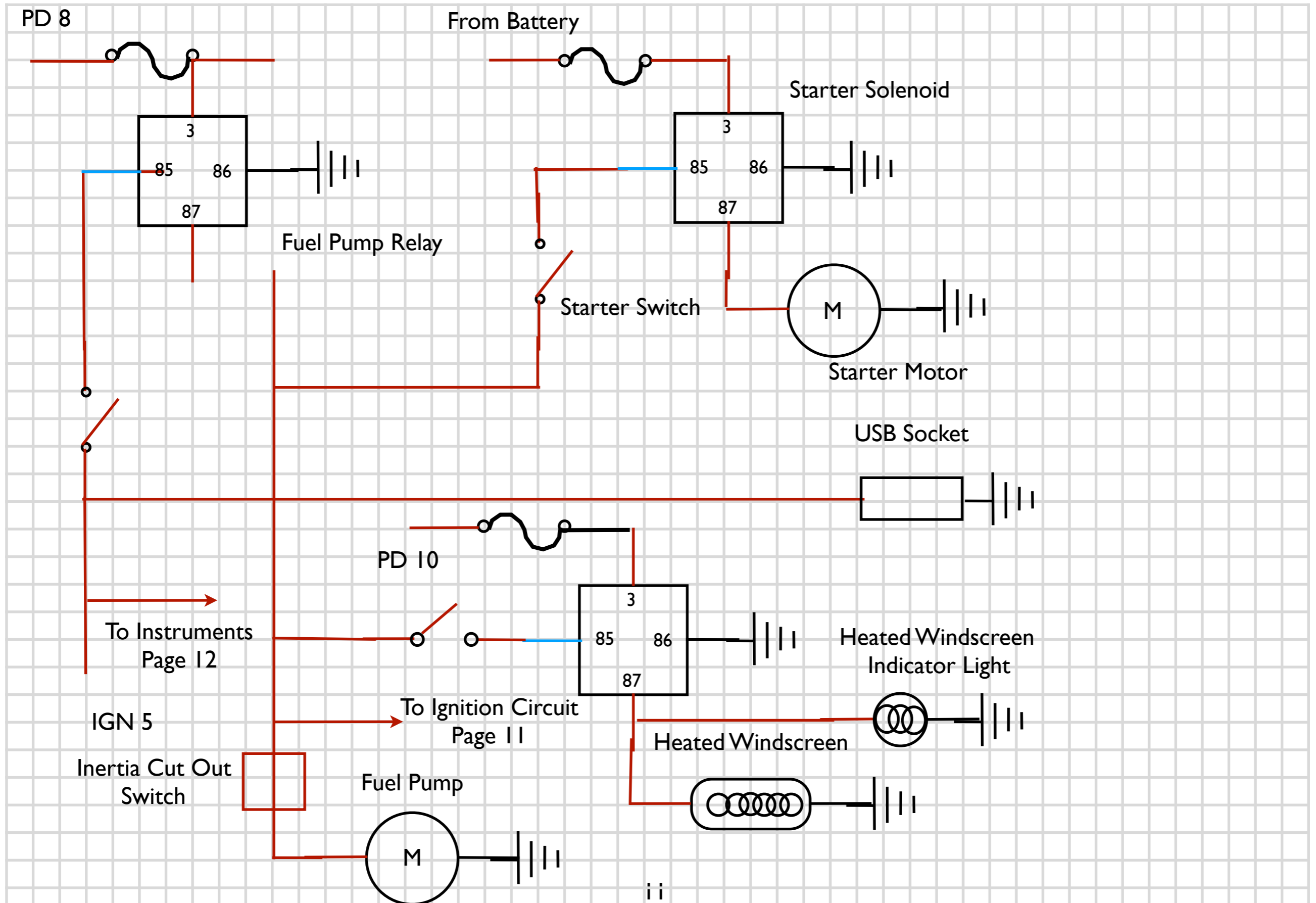

Porsche 914 GT Replica Wiring Diagrams

Circuit II - Horn

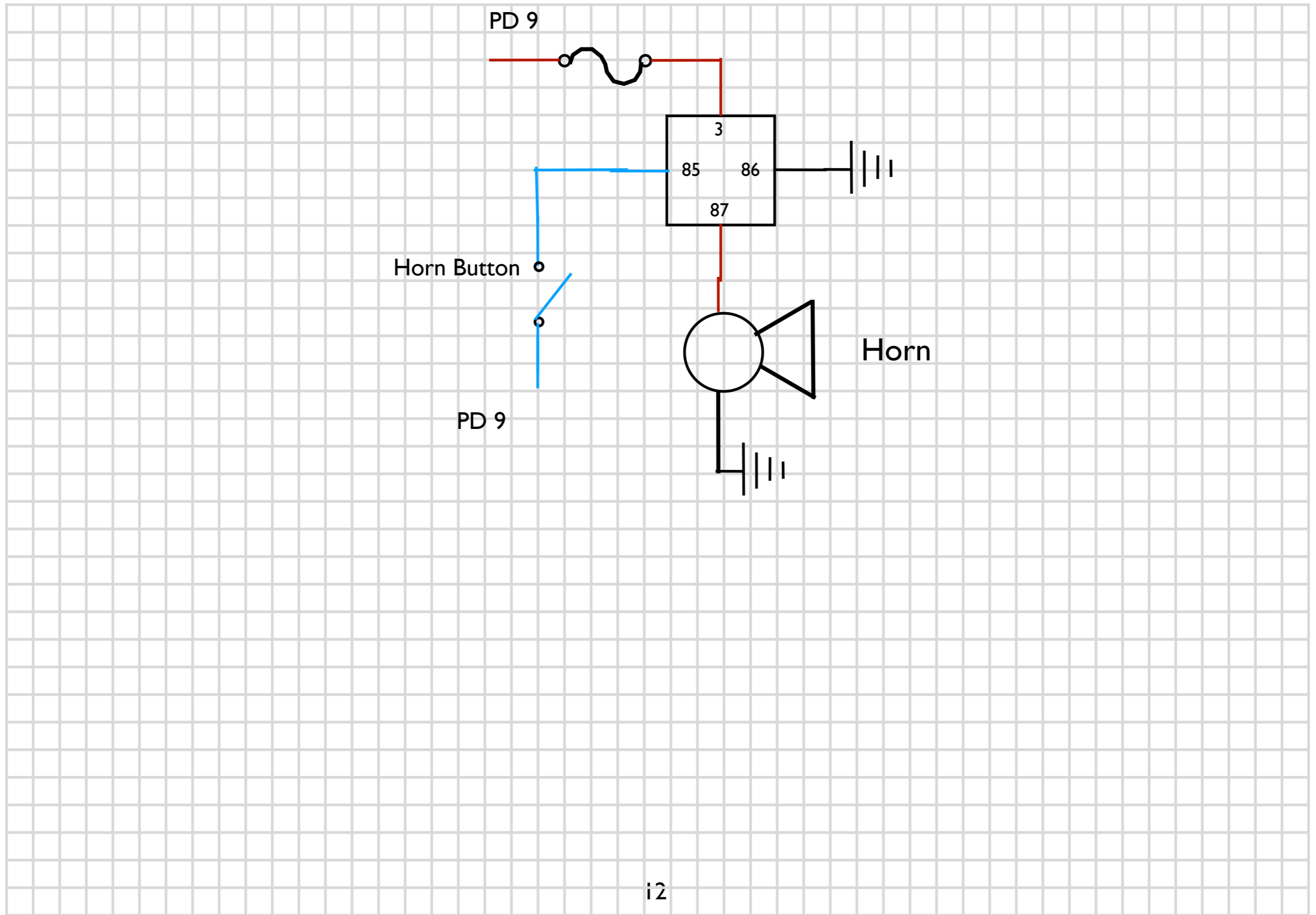

Coil/Distributor/Tachometer

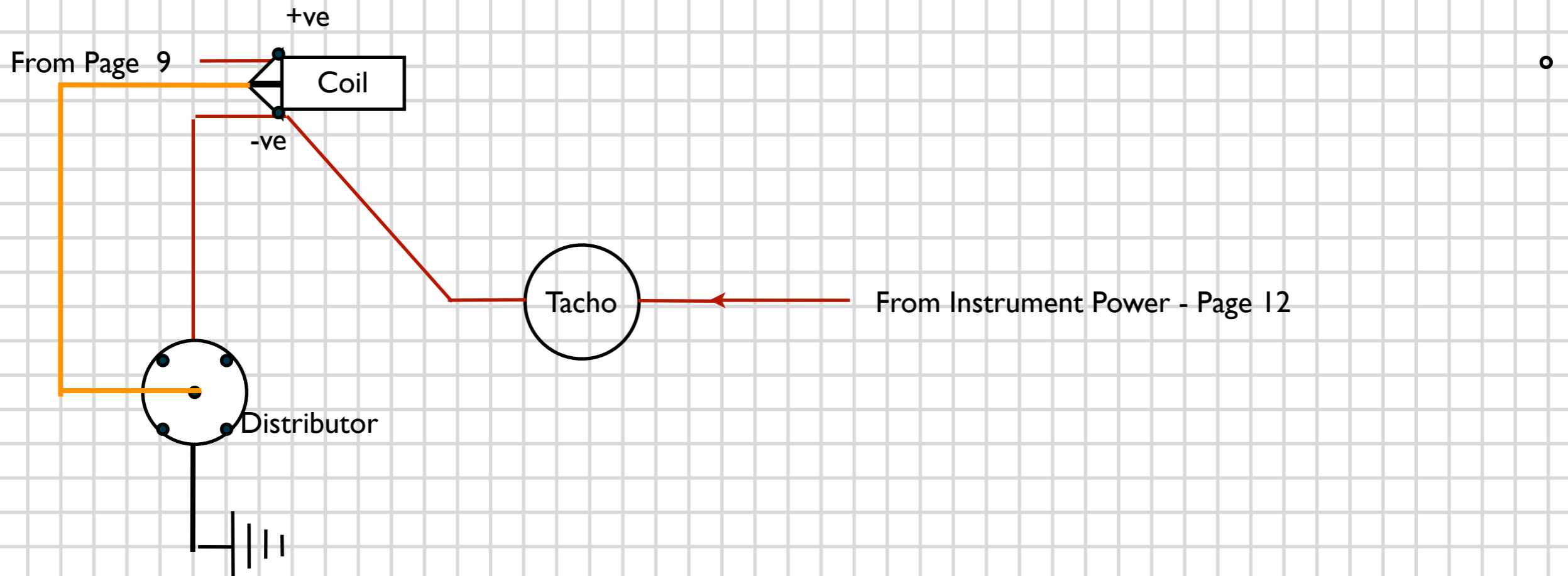

Porsche 914 GT Replica Wiring Diagrams

Instruments

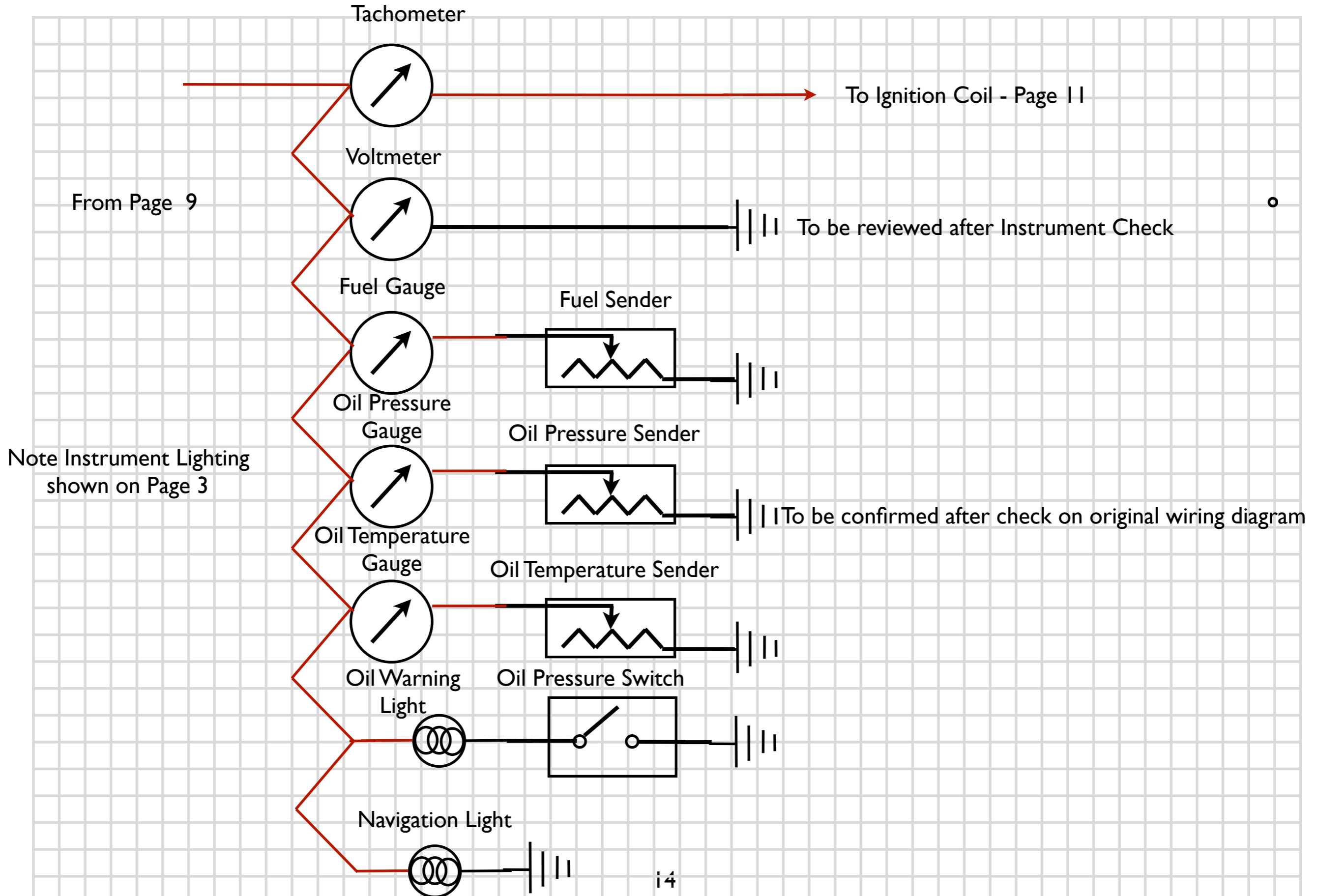

Electrical Matrix

914 GT Replica - Electrical Matrix - Final					
System	Breaker	Relay	Indicator Light	Switch	
SL	TRUE	FALSE	FALSE	FALSE	Porsche Switch
FO	FALSE	FALSE	TRUE	TRUE	
NL	FALSE	FALSE	FALSE	TRUE	
IG	TRUE	FALSE	FALSE	FALSE	Ignition/Starter
IN	TRUE	FALSE	FALSE	FALSE	Column Stalk
RB	FALSE	FALSE	FALSE	FALSE	Remote switches
HL	TRUE	4x	TRUE	FALSE	Porsche Switch
SP	FALSE	FALSE	TRUE	TRUE	
WW	TRUE	3x	FALSE	FALSE	Column Stalk
WA	FALSE	TRUE	FALSE	FALSE	Column Stalk
FP	TRUE	TRUE	TRUE	TRUE	
PS	FALSE	FALSE	FALSE	FALSE	
HW	TRUE	TRUE	TRUE	TRUE	
HO	TRUE	TRUE	FALSE	FALSE	Push Button
	8	11	5	5	